

Do Citrus Fruits Impact A Salt Water Battery?

National Science Fair Research Paper

Level : Middle Level

Category : Physical Science

Submitted by

JN Maryam Fathima

(Grade VI)



ARRAHMAAN
INTERNATIONAL SCHOOL

(Creating the community of Excellence)

Do Citrus Fruits Impact A Salt Water Battery?

CONTENTS

Chapter No	Title	Page NO
1	Abstract	3
2	Introduction	4
3	Statement Of the Problem	10
4	Hypothesis	10
5	Design Of Study	11
6	Collections of Data	
	• Photographs	16
	• Tabulation	35
	• Graphical Representation	39
7	Results and Discussion	43
8	Conclusion	44
9	Application	44
10	Future Enhancement	45
11	Acknowledgement	46
12	Reference	47

Do Citrus Fruits Impact A Salt Water Battery?

ABSTRACT

Can you imagine how your life would change if batteries did not exist? Batteries power many things around us; including cell phones, wireless video game controllers, and smoke detectors. Many of us know, we can make a battery out of a piece of fruit. Generally, any material having ions can conduct electricity when suitable electrode is provided. In the same way, having acidic juices, citric fruits can also conduct electricity. But how about teaming up fruits with saltwater? Will there be any impact?

I have done such combination of batteries in this project. At first, I prepared saltwater electrolyte by mixing 20g of salt in 400 ml of tap water. I had taken the extracts of three citrus fruits such as lemon, orange, and tomato. I mixed 90ml of salt solution and 10ml of fruit extract to make each of the Saltwater-Fruit combos and transferred to the respective glasses. I also kept 90ml salt solution in a different glass as my control. Connections were made by keeping copper as cathode and Zinc as anode. Before proceeding, I checked the working of my combos and saltwater battery with the help of piezoelectric buzzer. Then, I noted the open-circuit voltage and short-circuit current (mA) for all the electrolytes without any treatment. Then, I treated the electrolytes by stirring with straw and then by blowing through straw throughout the project. I noted the open-circuit voltage and the short-circuit current (mA) for both cases. Short-circuit current was noted at once and then for consecutive three minutes and the average reading was recorded.

Through this project, I observed that when the electrolytes blown with straw show the greatest current reading. Among all, Lemon-salt combo produces the highest Short-circuit current (average) whereas Tomato-salt combo produces the least.



INTRODUCTION

Working Principle of Battery:

As a result of the oxidation reaction, one electrode gets negatively charged called cathode and due to the reduction reaction, another electrode gets positively charged called anode. The cathode forms the negative terminal whereas anode forms the positive terminal of a battery. To understand the **basic principle of battery** properly, first, we should have some basic concept of electrolytes and electrons affinity. It is found that, when some specific compounds are added to water, they get dissolved and produce negative and positive ions. This type of compound is called an electrolyte. If two different kinds of metals are immersed in the same electrolyte solution, one of them will gain electrons and the other will release electrons. Which metal (or metallic compound) will gain electrons and which will lose electrons, depend upon the electron affinity of these metals. The metal with low electron affinity will gain electrons from the negative ions of the electrolyte solution. On the other hand, the metal with high electron affinity will release electrons and these electrons come out into the electrolyte solution and are added to the positive ions of the solution.

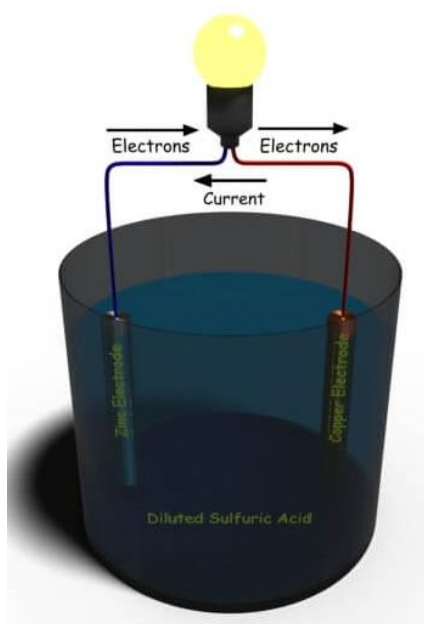

Every battery is made up of anode, cathode, and an electrolytic solution. Anode and cathode are electrodes (electricity conducting material through which electric charges or current can flow) that are submerged in the electrolytic solution and connected externally through a conducting wire. On being dissolved in the solvent, electrolyte releases ions. And we know that moving ions or electrons

produces electric current. Let's see how. The ions released by the electrolyte react with the anode to release one or more electrons. As electrons accumulate near the anode, they start moving through the wire towards the cathode, which has no or very few electrons. This movement of electrons produces electric current that powers any gadget connected through the wire.

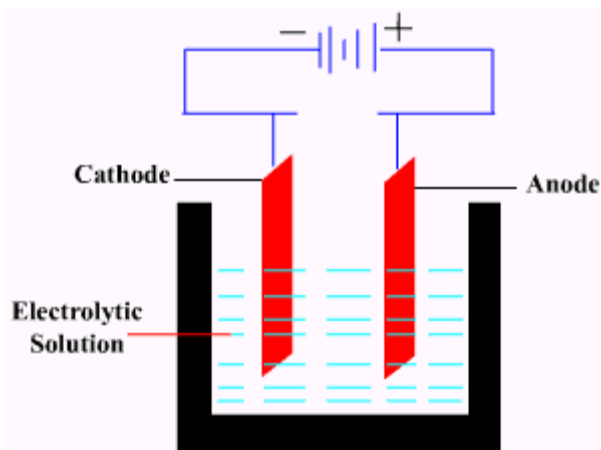

How Saltwater acts as electrolyte?

Water is a compound that has strong "bonds" among its constituents. In other words, it is difficult to break apart the hydrogen and oxygen atoms without some sort of energy input. "Salts," on the other hand, usually have weak "bonds" and the atoms of salts can easily be separated into its appropriate ions. When a salt, like sodium chloride (table salt) is dissolved in water the sodium and chloride separate temporarily. The sodium atom will become a positively charged ion and the chloride atom will become a negatively charged ion. An ion is an atom or group of atoms that has a negative or positive electric charge. Negative ions are formed by atoms gaining electrons, and positive ions are formed by atoms losing electrons.

Substances that conduct electric current are called electrolytes. They are formed as a result of a dissociation into positively and negatively charged particles called ions, which migrate toward and ordinarily are discharged at the negative and positive terminals of an electric circuit, respectively. The most familiar electrolytes are acids, bases, and salts, which ionize when dissolved in such solvents as water. Many salts, such as sodium chloride, behave as electrolytes when dissolved in water. Pure water will not behave as an electrolyte.

Salt water is made up of sodium chloride and water. When salt is added to water, the sodium and chloride ions float freely in the water. Since an ion has an electrical charge, it can carry electricity through water. If a circuit is connected with an electricity source and a light bulb, it is possible to light the bulb using the salt water as a conductor.

Fruit Battery

Citrus fruits are acidic, and whenever any metal comes in direct contact with acid, the atoms of the metal give up electrons. The acidity of citrus fruit juice acts as an electrolyte that conducts electricity. Further, the aqueous environment of the fruit, to a certain extent, mimics the conducting chemical of the battery, and the electrons start flowing through the circuit.

Citrus fruits such as oranges, grapefruits, limes and lemons have high acidity levels. One lemon can produce 7/10 of one volt of electricity. Electrical power increases as you connect more fruits. The average **lemon** output is .9 volts at .00024 **amps** — or about .000216 watt. It takes about four or five **lemons** to power a single red LED (1.5 volts). To make this work, you'll need to make three or four more **lemon batteries** and then connect them together in a series.

The stronger the acid in an electrolyte, the better the electrolyte will conduct electricity and the stronger the battery will be. When it comes to citrus fruit, taste is a good indicator of acid strength, because strong acids taste sourer than weak ones. Lemons and limes are sourer than oranges and thus make better batteries, and because citric acid decays into fructose and other sugars as fruit ages, young fruit fresh off the tree is better than fruit left sitting on a shelf. Besides lemons, limes and oranges, you can also make batteries out of young apples and potatoes.

How a Fruit Battery Works

The following chemical reactions occur in a fruit battery

- The copper and zinc metals act as positive and negative battery terminals (cathodes and anodes).

- The zinc metal reacts with the acidic juice (mostly from citric acid) to produce zinc ions (Zn^{2+}) and electrons ($2 e^-$). The zinc ions go into solution in the juice while the electrons remain on the metal.
- The wires of the small light bulb are electrical conductors. When they are used to connect the copper and zinc, the electrons that have built upon the zinc flow into the wire. The flow of electrons is current or electricity. It's what powers small electronics or lights a light bulb.
- Eventually, the electrons make it to the copper. If the electrons didn't go any farther, they'd eventually build up so that there wouldn't be a potential difference between the zinc and the copper. If this happened, the flow of electricity would stop. However, that won't happen because the copper is in contact with the electrolyte.
- The electrons accumulating on the copper terminal react with hydrogen ions (H^+) floating free in the acidic juice to form hydrogen atoms. The hydrogen atoms bond to each other to form hydrogen gas.

Why Salt-Fruit Combo?

Water is inexpensive, available everywhere, non-flammable and can conduct ions. However, water has one major drawback: It is chemically stable only up to a voltage of 1.23 volts. In other words, a water cell supplies three times less voltage than a customary lithium ion cell with 3.7 volts, which makes it poorly suited for applications in an electric car. A cost-effective, water-based battery, however, could be extremely interesting for stationary electricity storage applications. In order to increase this value, there are two ways—either the salt containing electrolyte has to be liquid, and it has to be so highly concentrated or the acidity of the solution should be increased which will increase the efficiency.

Fruits soaked in brine or otherwise pickled, such as pickles, conduct electricity due to their salt content. Salt is high in ions and conducts electricity. Fruits high in salt content will produce electricity.

Basic Terminologies:

The flow of electricity is called an electrical **current**, which is measured in a unit called **amperes (A)** (also called **amps** for short). **Voltage**, measured in **volts (V)** is what pushes electrical current through wires.

Finally, electrical **resistance**, measured in **ohms (Ω)** (the capital Greek letter Omega) is a measure of how difficult it is for electricity to flow through a certain material.

Quantity	Unit	Description
Current	Ampere (A)	The "flow" of electricity
Voltage	Volt (V)	The "pressure" that makes electricity flow
Resistance	Ohm (Ω)	How hard it is for electricity to flow through something

Open circuit and closed circuit:

Batteries have positive and negative terminals. In order for electricity to flow in a battery-powered circuit, there must be a complete path from the positive terminal, through the load, and back to the negative terminal. This is called a closed circuit. If the path is broken (for example, if one wire is disconnected), electricity cannot flow. This is called an open circuit. Finally, if there is a direct path from the positive to the negative terminal, this is called a short circuit. Short circuits are bad because they can cause batteries to drain very quickly and overheat

Series Vs Parallel connections

Multiple batteries can be connected two different ways: in series or in parallel. When multiple batteries are connected in series, the positive terminal of one battery is connected to the negative terminal of the next battery (and this repeats if there are more than two batteries). When batteries are connected in parallel, all of the positive battery terminals are connected together, and all of the negative battery terminals are connected together.

Open circuit voltage:

Open-circuit voltage is the voltage across a battery's terminals when it is not attached to anything. This is the highest voltage that a battery can supply (the voltage will drop slightly when the battery is attached to a load).

Short-circuit current:

The short-circuit current is the current when the battery's terminals are shorted together. This is the highest current the battery can supply (the current will also drop when the battery is attached to a load).

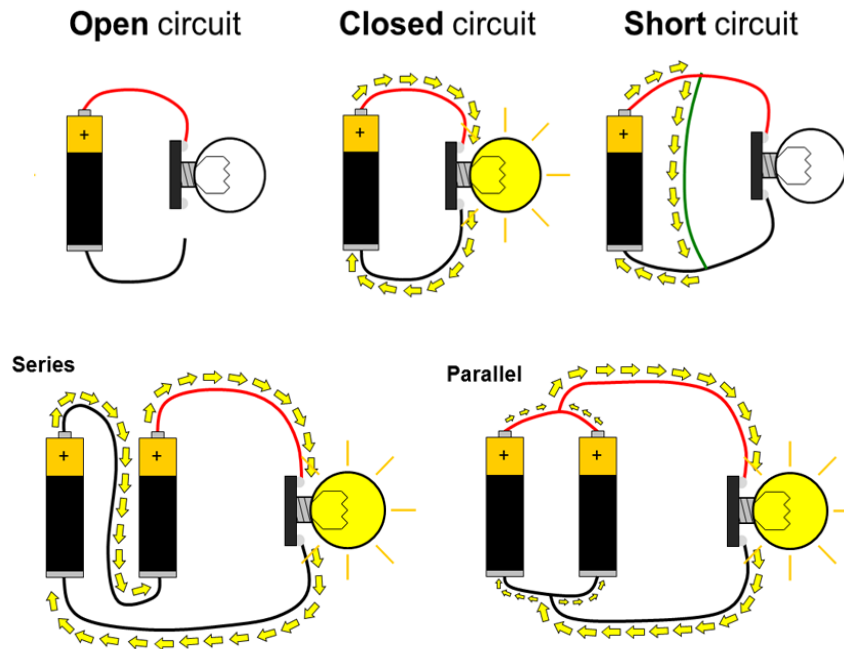

STATEMENT OF THE PROBLEM

Climate change is making its impact felt world-wide. Yet carbon dioxide emissions keep increasing. When we burn coal to produce electricity, large quantities of carbon dioxide are expelled into our atmosphere. Though batteries are on one-army mission, Saltwater could be the best economical energy source for homes and factories. The question is, “To what extent is it possible to increase their current generating efficiency by adding citrus juices?”

HYPOTHESIS

Lemon-Salt Combo will be the best battery among all other fruit-salt combos.

DESIGN OF STUDY

INDEPENDENT VARIABLE:

- Nature of electrolyte (fruit combo)

DEPENDENT VARIABLE:

- Current flow

CONTROLLED VARIABLES:

- Quantity of electrolyte
- Dimensions of electrodes
- Experimental conditions

MATERIALS:

- Copper electrodes (4)
- Zinc electrodes (4)
- Alligator clip leads (4 sets)
- Digital multimeter with test leads
- Piezoelectric buzzer
- Glass tumblers (4)
- Rock salt (Sodium Chloride)
- Citrus fruits (Lemon, Orange, Tomato)
- Measuring cup, metric – 100ml, 50ml
- Beaker
- Bowl for weighing
- Paper cup
- Teaspoon
- Tap water
- Digital balance
- Paper Straw
- Knife
- Filter
- Hand-juicer
- Tray
- Paper towels for cleanup of any spills
- Timer or watch with second hand
- Pen
- Permanent marker and label
- Lab notebook

PROCEDURE:

- Once the needed materials are collected, select a suitable place where battery setup will be undisturbed.
- Label the 4 glass tumblers as Salt water, Salt water + lemon, Salt water + orange, Salt water + tomato
- Make a data-table accordingly.

Preparation of electrolyte:

A. Saltwater electrolyte:

- Place the weighing cup on the digital scale and tare the scale.
- Weigh 20 grams of rock salt (NaCl).
- Fill the beaker with 400mL of tap water using measuring cup.
- Add the weighed salt to the water in the beaker.
- Stir the solution with a clean spoon **until all salt is dissolved**.
- Pour 90 ml in all the 4 glasses.
- The amount of salt needed to attain the concentrated (saturated) solution may be decided after a trial and error.

B. Fruit electrolytes:

- Select the citrus fruits which are more acidic –lemon, orange and tomato.
- Collect some fresh juice from the fruits in the concentrated form (without adding water) with the help of hand-juicer.
- Filter for any seeds.

C. Fruit-Salt Combo:

- Prepare fruit-salt combo by mixing fruit juice with saltwater as follows:
 - Measure 10 ml of lemon juice and pour into the glass labelled SW+Lemon.
 - Measure 10 ml of orange juice and pour into the glass labelled SW+Orange.
 - Measure 10 ml of tomato juice and pour into the glass labelled SW+Tomato.

Setting up:

- Get electrodes ready. The shiny reddish electrode is the Copper (Cu) electrode and it will be the cathode. The silver-looking electrode is the Zinc electrode(Zn) which will be anode.
- Label each of the 4 Copper and 4 Zinc as 1,2,3,4. Weigh them separately and enter into the tabulation.
- Observe the appearance, surface roughness, lustre and take a picture of the electrodes before beginning the project. This is necessary for the comparison of the same at the end.
- In each of the glasses, insert zinc and copper electrode respectively. Place them on opposite sides of the glass so they face each other. Be careful not to knock over the cups. The electrodes should remain in the electrolyte throughout the entire experiment. Make sure that they *never* touch each other to prevent an accidental short circuit.

Testing the battery:

- Now test the batteries for their working.
- Connect one end of the black alligator cable to the zinc anode. Use the clip to attach the electrode to the glass wall for grip. Then take the red alligator clip cable and connect one end of the cable to the copper cathode. Again, attach the electrode to the glass wall with the clip to hold it in place.
- Get the piezoelectric buzzer (round-shaped black object) from the kit. Connect the second end of the red alligator clip cable to buzzer's positive (red) wire, and the black alligator clip to the buzzer's negative (black) wire.
- If the setup battery is working, loud noise from buzzer could be heard. If sound is not heard, check the battery setup and all the cable connections. Make sure the buzzer is not connected backwards by getting red and black wires mixed up.
- Remove the buzzer from the alligator clip cables before continuing with the next step.

Measuring Voltage and Current Output

- Record the open-circuit voltage (the voltage across both electrodes when no current is flowing) and the short circuit current (the current when the battery's electrodes are shorted together) for each of the batteries under different experimental conditions.

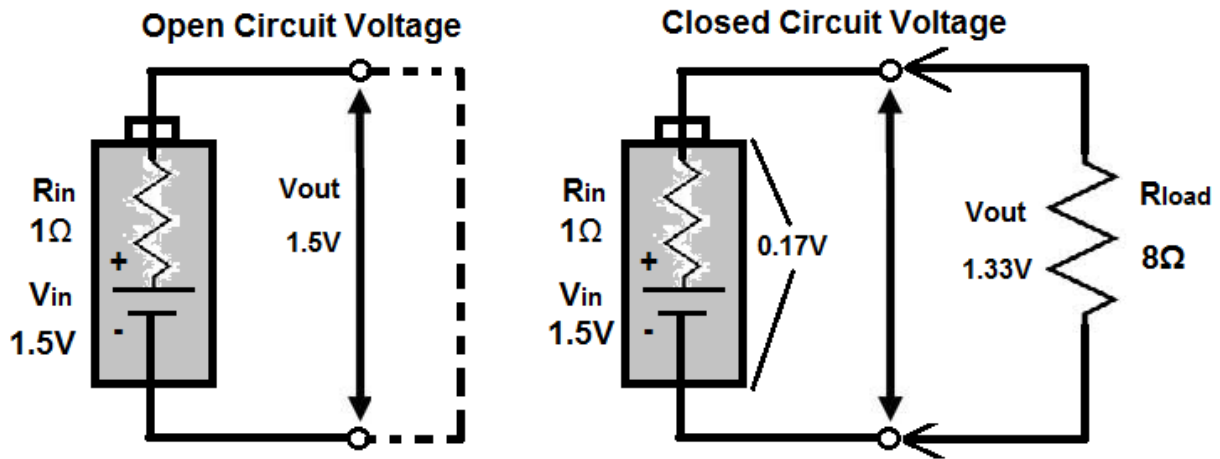

Experimental conditions:

a) No treatment:

- Measure the open-circuit voltage and short circuit current of each of the batteries. Start with the first one and start with other two trials. These values give us the highest voltage and the highest current that our battery can supply.
- a. Connect the alligator clip cables that are still connected to the electrodes to the multimeter leads.
 - i. First, plug the red multimeter probe into the multimeter port labeled $V\Omega mA$, and the black multimeter probe into the multimeter port labeled COM.
 - ii. Now clip the end of the red alligator clip cable (still connected to copper electrode) onto the metal part of the red multimeter probe.
 - iii. Finally, clip the end of the black alligator clip cable (still connected to zinc electrode) onto the metal part of the black multimeter probe.
 - b. Set the multimeter dial to measure in the 20 V range (the "20" in the upper left of dial). Record the open circuit voltage in the data table (table).
 - c. Change the multimeter dial to measure in the 200mA range (the "200m" on the right side of the dial). Quickly record the short-circuit current in the data table. The current will start to drop rapidly as the battery begins to drain and the oxygen dissolved in the electrolyte gets depleted.
 - d. Then set the timer to 3 minutes and record the short-circuit current for every minute totally for 3 minutes. These will be your results for the "no treatment" batteries.

b) Continuous stirring with straw

- a. Once finished measuring the open-circuit-voltage and short-circuit-current of all batteries, you are ready to start with the first battery and repeat the procedure with the other two afterwards.
- b. Keep the multimeter dial set to measuring direct current in the 200mA range (the green “200m” on the right side of the dial). The readings should still be very low and fairly stable from the previous measurements. If the current is still rapidly decreasing, wait 1 to 3 minutes until the reading has stabilized and does not change much any more.
- c. Take the paper straw and stir the solution (electrolyte) in the cup without knocking the cup over. It is okay to touch the electrodes with the straw, but do not bump them too hard.
- d. Right after starting stirring; note the short-circuit-current readings on the multimeter display. They probably will fluctuate a lot. In your data table, write down the highest current reading that you see during stirring.
- e. Keep stirring and set the timer to 3 minutes. Notice that the current readings will still fluctuate. After 3 minutes of treatment, while still stirring, record the highest reading of the short-circuit current in the data table.
- f. Set the multimeter dial back to measure in the 20 V range (the “20” in the upper left of the dial). Repeat the stirring procedure and observe the voltage readings on the multimeter. Write down the reading during stirring.

c) Continuous blowing bubbles with straw

- Next, continue with the second mechanical treatment. Repeat the step 3, but this time instead of stirring the electrolyte with the straw use the straw to blow bubbles into the solution.
- While blowing, hold the straw close to the copper electrode, as this is where the dissolved oxygen get reduced.

Short circuiting

After finishing, to visualise a more obvious electrode change let the salt water battery run for longer in short-circuit mode, keep the electrode in the salt water and fruit-combos with the alligator clip cable attached. Disconnect the multimeter leads, and then connect the free ends of the red and black alligator clips directly to each other. After two days, take the electrode out and assess the condition again.

COLLECTION OF DATA- PHOTOGRAPHS





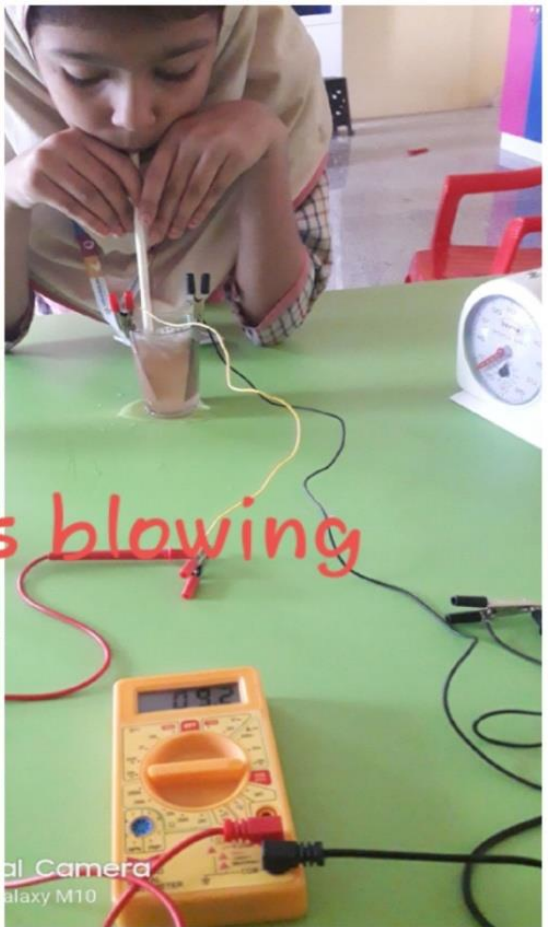
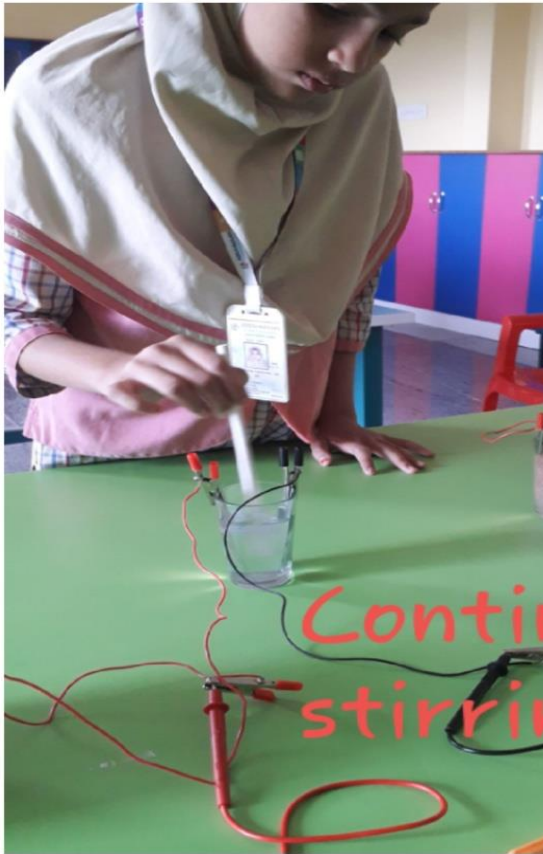

Samsung Dual Camera
Shot with Murshi's Galaxy M10

al Camera
galaxy M10

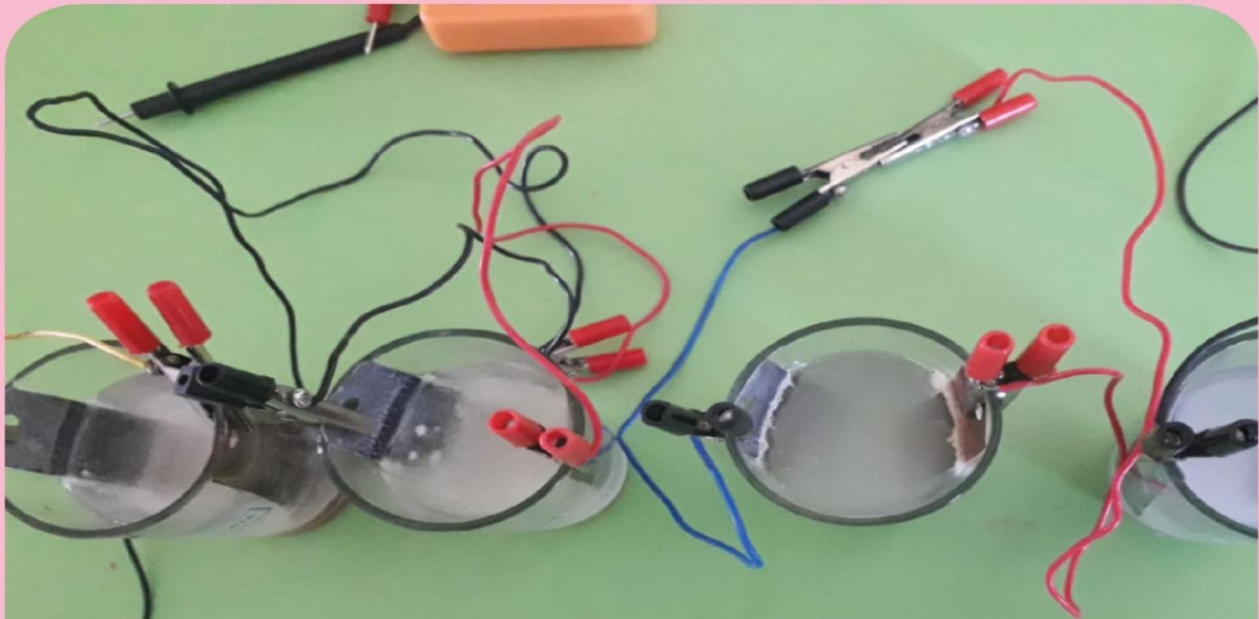

Short circuiting for testing after 2 days

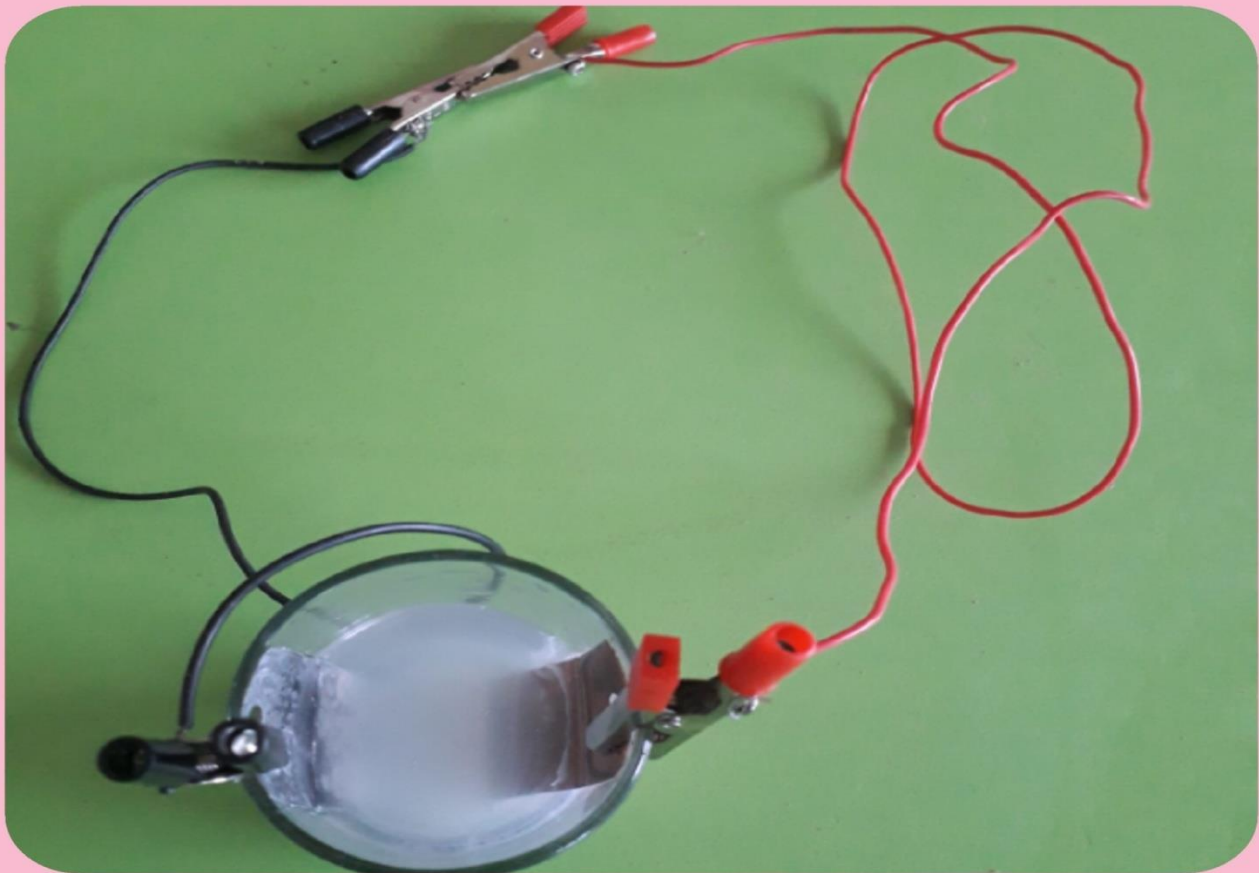



Observing
roughness
(After)

Samsung Dual Camera
Shot with Murshi's Galaxy M10

Samsung Dual Camera
Shot with Murshi's Galaxy M10





Samsung Dual Camera
Shot with Material's Gallery V10

Salt water



Sw+Lemon



After

Samsung Dual Camera
Shot with Material's Gallery M10

Sw+Orange



Sw+Tomato



Samsung Dual Camera
Shot with Metadata Galaxy M10

Salt water



Sw+Lemon



After

Samsung Dual Camera
Shot with Metadata Galaxy M10

Sw+Orange



Sw+Tomato



Tabulation

TABLE 1: COMPARING ELECTRODE CONDITIONS AT THE BEGINNING AND END OF THE EXPERIMENT

Metal Electrodes	Cathode (Cu)				Anode(Zn)			
	SW Cu	SW+L Cu	SW+O Cu	SW+T Cu	SW Zn	SW+L Zn	SW+O Zn	SW+T Zn
Electrode Condition at the Beginning								
Weight (in g)	3	3	3	3	5	5	5	5
Colour	Reddish Brown				Silver			
Surface roughness	Smooth				Slightly rougher than copper			
Lustre	Shiny				Comparatively less			
Electrode Condition at the End								
Weight (in g)	4	4	3	3	6	6	5	5
Colour	White layer deposition in the immersed marking line	White layer deposition in the immersed marking line Not much change in colour	Slight corrosion, Brownish colour spots	Black colour lines in some areas	White layer deposition in the immersed marking line	Yellow layer deposition in the immersed marking line	Whitish deposition in some areas	Black colour lines in some areas
Surface roughness	Loss of Smoothness	Smooth	Rough	Rough	Not much change	Not much change	Not much change	Not much change
Lustre	Dull, foggy layer	No change	Dull	Dull	Dull	Dull	Dull	Dull

2. OPEN-CIRCUIT VOLTAGE AND SHORT-CIRCUIT CURRENT FOR DIFFERENT ELECTROLYTES UNDER DIFFERENT EXPERIMENTAL CONDITIONS

TABLE 2A: WORKING OF FRUIT-SALT COMBO WITHOUT ANY TREATMENT

Electrolyte	Without any treatment					
	Open-circuit voltage (V)	Short circuit current (mA)				
		At once	After 1minute	After 2 minutes	After 3 minutes	AVERAGE
Saltwater	0.79	21.0	4.0	2.9	2.6	3.166667
Lemon added saltwater	0.76	36.6	17.8	16.3	15.7	16.6
Orange added saltwater	0.88	39.4	4.6	3.6	3.2	3.8
Tomato added saltwater	0.86	18.4	3.4	2.9	2.6	2.966667

TABLE 2B: WORKING OF CONTINUOUSLY STIRRED FRUIT-SALTCOMBO

Electrolyte	Continuous stirring with straw					
	Open-circuit voltage (V)	Short circuit current (mA)				
		At once	After 1minute	After 2 minutes	After 3 minutes	AVERAGE
Saltwater	0.86	99	7.3	6.7	5.6	6.533333
Lemon added saltwater	0.76	53	22.8	23.1	22.5	22.8
Orange added saltwater	0.87	74	7.6	7.0	6.7	7.1
Tomato added saltwater	0.79	12	5.7	5.7	5.6	5.666667

TABLE 2C: WORKING OF CONTINUOUSLY BLOWN FRUIT-SALTCOMBO

Electrolyte	Continuous blowing bubbles with straw					
	Open-circuit voltage (V)	Short circuit current (mA)				
		At once	After 1minute	After 2 minutes	After 3 minutes	AVERAGE
Saltwater	0.81	145	9.2	7.7	9.2	8.7
Lemon added saltwater	0.72	186	22.3	22.0	22.6	22.3
Orange added saltwater	0.84	156	8.7	6.4	9.9	8.333333
Tomato added saltwater	0.78	112	10.0	8.8	10.0	9.6

TABLE 3: COMPARING OPEN-CIRCUIT VOLTAGE OF FRUIT COMBOS AT DIFFERENT EXPERIMENTAL CONDITIONS

Electrolyte	Open circuit voltage (V)		
	No treatment	Continuous stirring with straw	Continuous blowing bubbles with straw
Saltwater	0.79	0.86	0.81
Lemon added saltwater	0.76	0.76	0.72
Orange added saltwater	0.88	0.87	0.84
Tomato added saltwater	0.86	0.79	0.78

TABLE 4: COMPARING AT ONCE SHORT CIRCUIT CURRENT OF FRUIT COMBOS AT DIFFERENT EXPERIMENTAL CONDITIONS

<i>Electrolyte</i>	<i>At once short circuit current (Ma)</i>		
	<i>No treatment</i>	<i>Continuous stirring with straw</i>	<i>Continuous blowing bubbles with straw</i>
Saltwater	21.0	99	145
Lemon added saltwater	36.6	53	186
Orange added saltwater	39.4	74	156
Tomato added saltwater	18.4	12	112

TABLE 4: COMPARING SHORT CIRCUIT CURRENT OF FRUIT COMBOS AT DIFFERENT EXPERIMENTAL CONDITIONS

<i>Electrolyte</i>	<i>Average short circuit current</i>		
	<i>No treatment</i>	<i>Continuous stirring with straw</i>	<i>Continuous blowing bubbles with straw</i>
Saltwater	3.166667	6.533333	8.7
Lemon added saltwater	16.6	22.8	22.3
Orange added saltwater	3.8	7.1	8.333333
Tomato added saltwater	2.966667	5.666667	9.6

GRAPHICAL REPRESENTATION

Graph1: COMPARING VOLTAGE AND CURRENT OF ELECTROLYTES

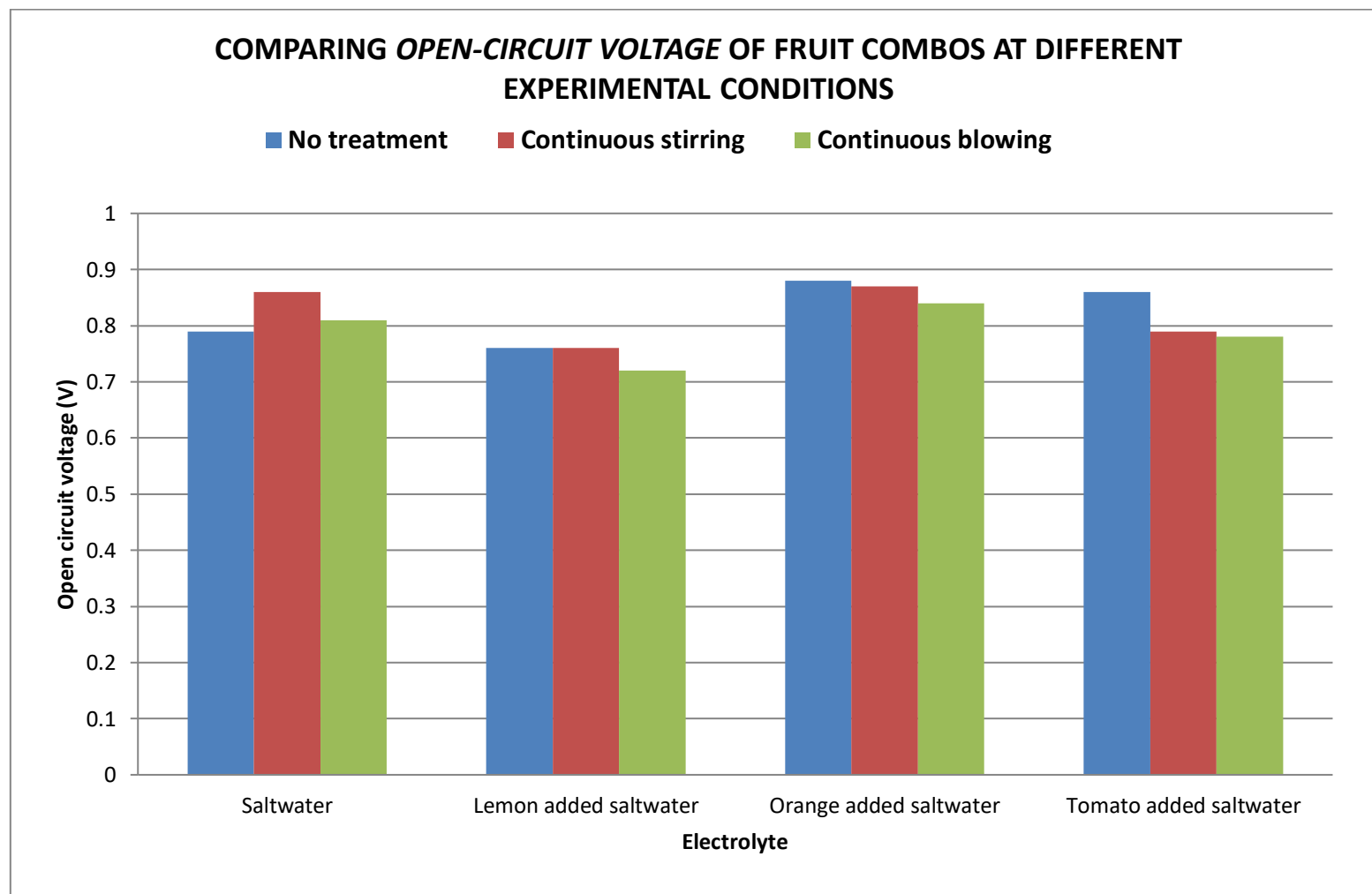

COMPARING *AT ONCE* SHORT CIRCUIT CURRENT OF FRUIT COMBOS AT DIFFERENT EXPERIMENTAL CONDITIONS

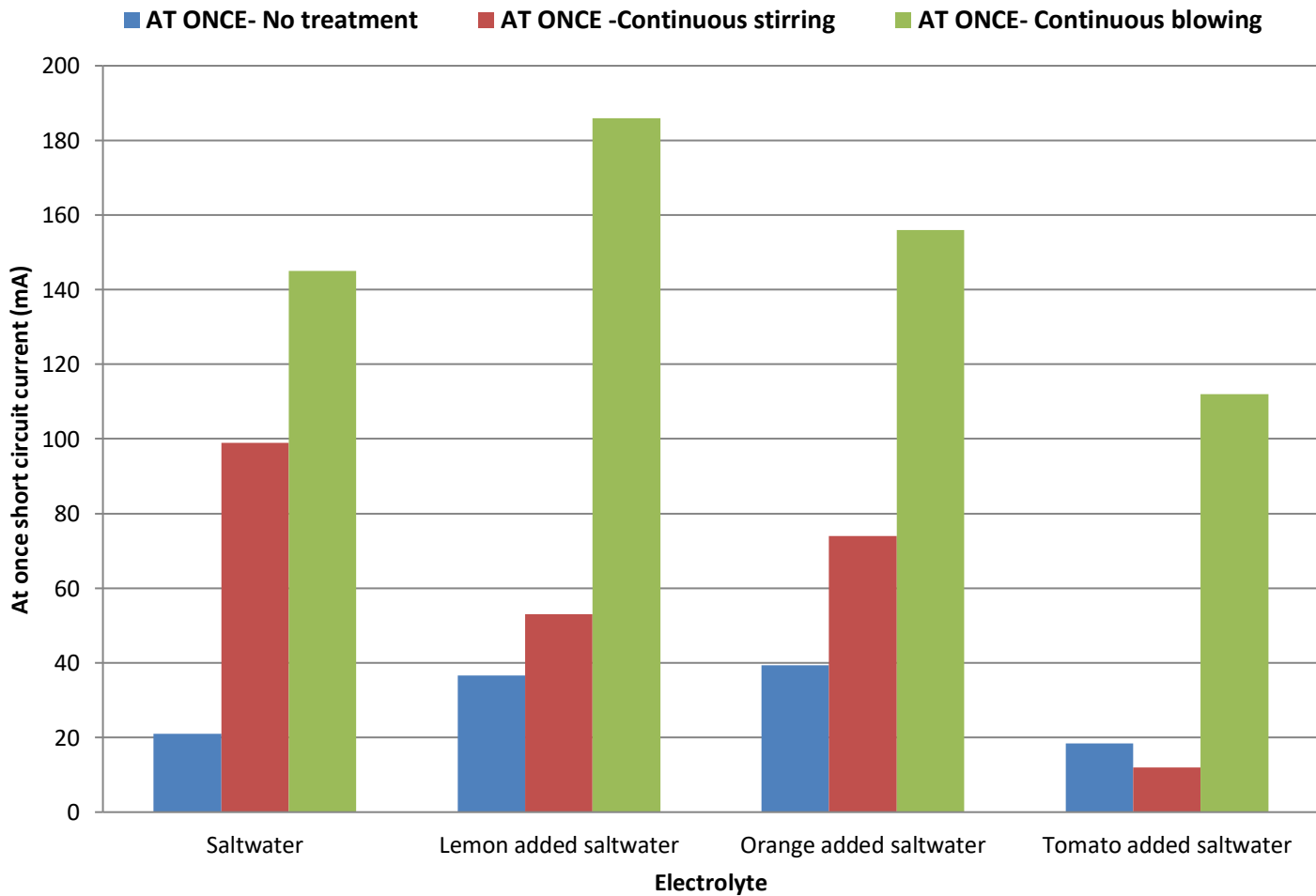

COMPARING AVERAGE SHORT CIRCUIT CURRENT OF FRUIT COMBOS AT DIFFERENT EXPERIMENTAL CONDITIONS

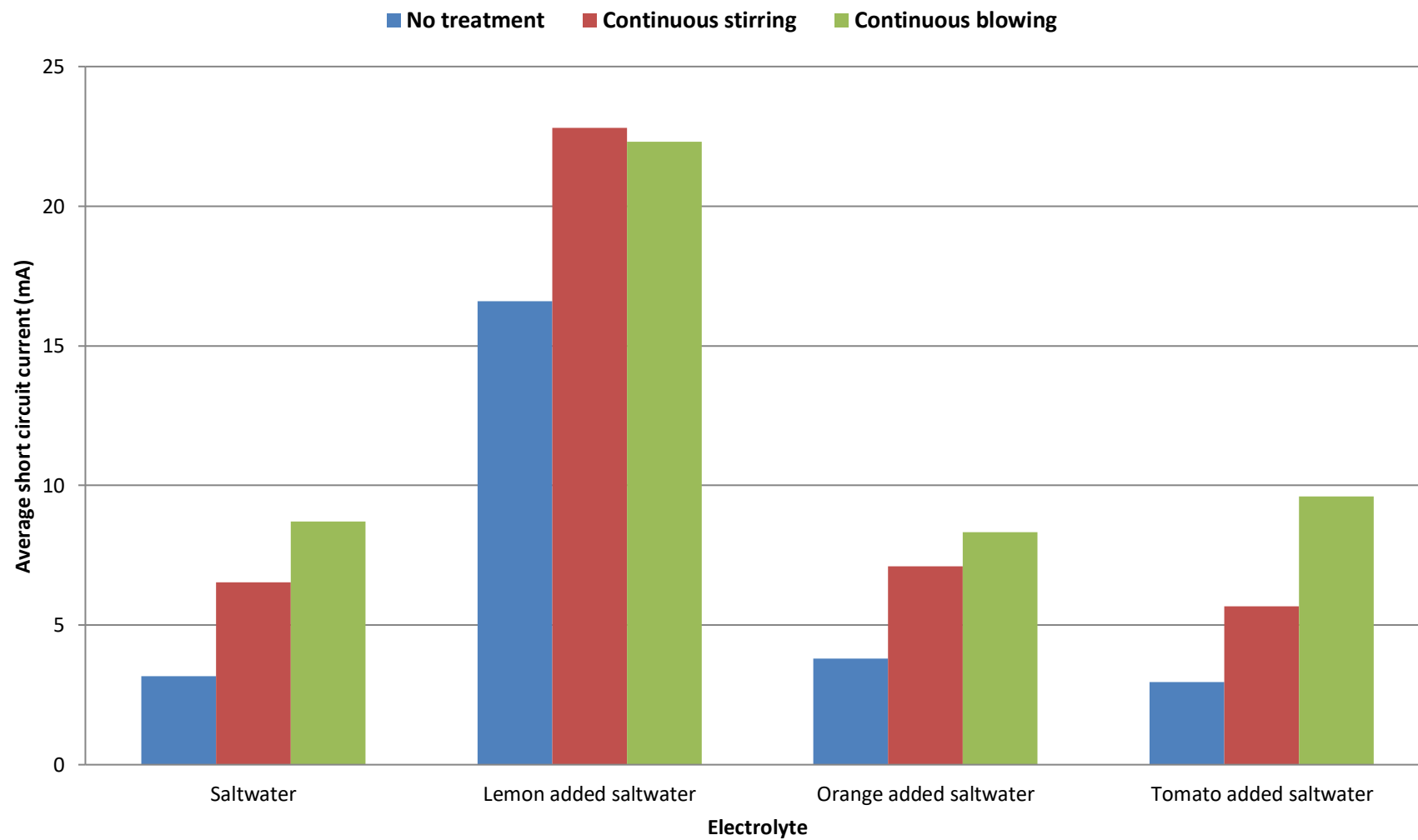

Graph 2: COMPARISON OF AT ONCE & AVERAGE SHORT CIRCUIT CURRENT OF FRUIT COMBOS AT DIFFERENT EXPERIMENTAL CONDITIONS

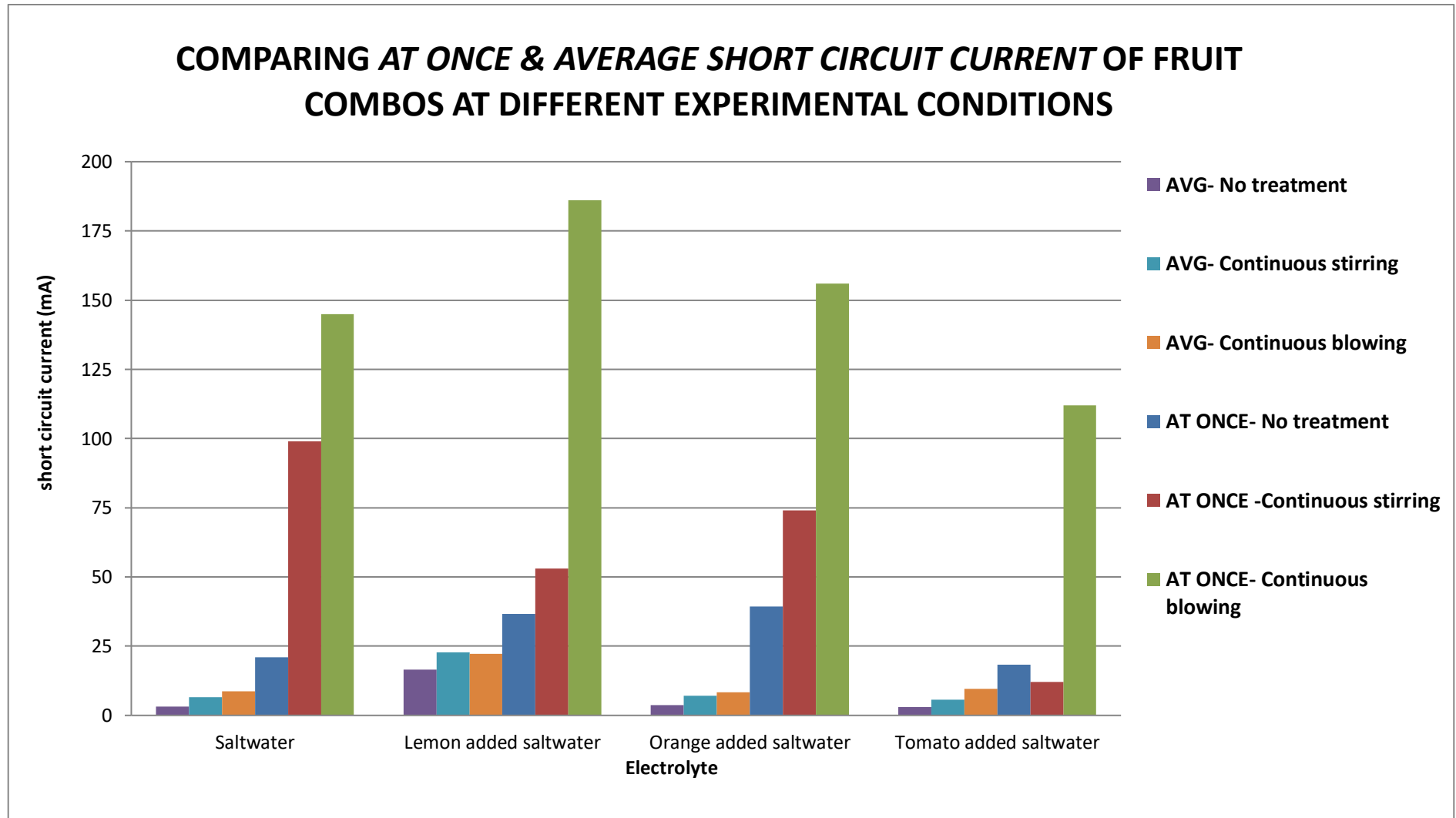

RESULTS AND DISCUSSION

- Open circuit voltage was high in Orange Saltwater battery, followed by Tomato mixed Saltwater, Saltwater and then Lemon -mixed saltwater at the least.
- The mechanical treatment does not impact much in Voltage reading.
- As an exact opposite, Short-circuit current has fluctuated a lot as a result of such treatment.
- In that too, Current taken at once was much greater than the same taken every minute (until 3minutes).
- Tomato salt combo has the least current flow maybe because of the extraction deposited at the bottom of the glass. I tried my best to mix it up well both in the cases of stirring and blowing.

Decreasing order of At Once Short circuit current in:

A. Without treatment

Orange mixed saltwater, Lemon mixed saltwater, Saltwater, Tomato mixed saltwater

B. Continuous stirring:

Saltwater, Orange mixed saltwater, Lemon mixed saltwater, Tomato mixed saltwater

C. Continuous blowing:

Lemon mixed saltwater, Orange mixed saltwater, Saltwater, Tomato mixed saltwater

Decreasing order of Average Short circuit current is the same for all the experimental conditions:

- 1. Lemon mixed saltwater**
- 2. Orange mixed saltwater**
- 3. Saltwater**
- 4. Tomato mixed saltwater**

IN A NUT-SHELL,

- **Saltwater is a neutral solution. When citrus fruit extract is added, it notably increases the production of electric current. Lemon is more acidic than orange, hence it got first place. Saltwater is preceding tomato added salt combo as tomato is the least acidic.**
- I noticed that it takes some start-up time for the lemon-salt combo to conduct well.
- I observed that when the electrolytes blown with straw show the greatest current reading.

Among all, Lemon-salt combo produces the highest Short-circuit current (average) whereas Tomato-salt combo produces the least.

CONCLUSION

My hypothesis, “Lemon-Salt Combo will be the best battery” has been proved. This is because with the addition of citrus fruits, the acidity of the salt water is increased, thus increasing the electric current. More current was produced when the electrolyte was continuously blown with straw.

APPLICATION

Advantages of salt water over other lithium-ion and lead-acid batteries are:

- ✚ Their low toxicity makes them more suitable for the most environmentally friendly battery.
- ✚ They can be fully discharged without suffering harm. This makes them very safe to transport and store.
- ✚ Unlike lithium-ion batteries they do not gradually decay over time when not in use and so a retailer could store them for months without affecting their warranty.
- ✚ Their ability to be completely discharged and left flat without suffering harm makes them particularly useful for any off-grid use where they may be left inactive for extended periods of time.
- ✚ They are more fire resistant.

FUTURE ENHANCEMENT

- I want to continue my project by making much perfect homogeneous mixtures avoiding the possible extent of deposition.
- I want to continue with varying ratio of juices and saltwater to obtain an optimum formula with greater efficiency.
- I want to make a study of longevity of such fruit-salt combo batteries by testing their % efficiencies.
- If possible, I want to look for a natural preservative to be added to the combo to increase their lifetime without affecting the conductivity.

ACKNOWLEDGEMENT

- Gratitude is the sign of Humanity”. It is not fulfilled without praising the Almighty, for giving me good strength throughout my research work and enabling me to complete the fair project successfully.
- I would like to express my deep thanks to my Correspondent **Mr.A.Sathakkathullah, M.Tech** and my Senior Principal **Mrs.A.ParakathNisha** for their constant support.
- I express my deepest sense of gratitude to my Principal **Mrs.R.SameemM.Sc, B.Ed, PGDCA**, and my guide teacher **Ms. K.Murshitha Shirin B.Tech,D.El.Ed.** for their guidance and valuable suggestions and developing my interest in the investigation and in the presentation of this report.
- I would like to thank my parents who helped and motivated me a lot for doing a science fair project.

REFERENCES

- <https://sciencing.com/do-citrus-fruits-produce-electricity-5167602.html>
- <https://www.electrical4u.com/battery-working-principle-of-batteries/>
- <http://www.upsbatterycenter.com/blog/electrolyte-battery-2/#prettyPhoto>
- <https://www.thoughtco.com/how-to-make-a-fruit-battery-605970>
- <https://www.scientificamerican.com/article/generate-electricity-with-a-lemon-battery/>
- <https://www.advancedsciencenews.com/salt-water-battery/>
- <https://sciencing.com/light-lightbulb-saltwater-8523885.html>
- <https://sciencing.com/do-citrus-fruits-produce-electricity-5167602.html>